

DATE: Feb.06.2006 PREPARED BY: Y.FUKUDA <i>Y. Fukuda</i>	SHARP SHARP CORPORATION 282-1 HAJIKAMI, KATSURAGI-SHI, NARA, 639-2198, JAPAN	SPEC No. TMVF06204
DATE: Feb.06.2006 CHECK BY: H.MAEDA <i>H. Maeda</i>		FILE No.
DATE: Feb.06.2006 APPROVED BY: T.HAYASHI <i>T. Hayashi</i>		ISSUE: Feb.06.2006
	SPECIFICATION	PAGE
		REPRESENTATIVE DIVISION ENGINEERING DEPT. II SOLAR SYSTEMS DIV.

SPECIFICATION FOR
SOLAR MODULE
MODEL No. NU-183E1

1. This specification sheets include the contents under the copyright of Sharp Corporation ("Sharp"). Please keep them with reasonable care as important information. Please don't reproduce or cause anyone reproduce them without Sharp's consent.
2. Please obey the instructions mentioned below for actual use of this module.
 - (1) Main applications of the modules as follows.

(Telemeter system, Microwave repeater station, Other telecommunication system (Terminal), Village electrification, Monument, Toy, etc.)
---	--	---
 - (2) Please take proper steps in order to maintain reliability and safety, in case this module is used for the uses mentioned below which require high reliability.

(Unit concerning control and safety of a vehicle (air plane, train, automobile, etc.), Traffic signal, Road sign, Security system, Other safety system, etc.)
---	--	---
 - (3) Please don't use for the uses mentioned below which required extremely high reliability.

(Space equipment, Telecommunication system (Trunk), Nuclear control system, Medical system (relating to any fatal element), etc.)
---	---	---

CUSTOMER'S APPROVAL

PRESENTED

DATE _____

BY *T. Hayashi* _____

BY _____

T.HAYASHI

Department General Manager

Engineering Dept. II

Revision Record

No.	DATE	CHANGE	PAGE	SIGNATURE		
				Approved by	Checked by	Prepared by
	Feb.06.2006	First Issue		T.Hayashi	H.Maeda	Y.Fukuda

1. SCOPE

This document describes the specifications of solar module NU-183E1

2. NORMATIVE REFERENCES

The following normative documents contain provisions which, through reference in this text, constitute provisions of this specification. At the time of publication, the editions indicated were valid. All normative documents are subject to revision, and parties to agreements based on this specification are encouraged to investigate the possibility of applying the most recent editions of the normative documents indicated below.

- IEC61215:04.1993 Crystalline silicon terrestrial photovoltaic (PV) modules-Design qualification and type approval
- IEC904-1 Photovoltaic Device, Part 1: Measurement of Photovoltaic Current-Voltage Characteristics
- IEC904-3 Measurement principles for terrestrial Photovoltaic(PV) solar devices with reference spectrum irradiance data
- SS-S Inspection 1000 Reference Photovoltaic module Rule
(SHARP Standard-Solar)
- TMSSF06012 SOLAR MODULE (Front View)
(Provided as Fig.1)
- TMSSF06013 SOLAR MODULE (Back View)
(Provided as Fig.2)

3. REQUIREMENTS

3.1 Materials

The materials used for the module shall comply with this specification and unless otherwise specified, the ones that fully meet the requirement of this specification shall be used in any case.

3.1.1 Solar cells

Solar cells shall be produced from single-crystalline silicon.

3.1.2 Interconnectors

Interconnectors shall be solder coated copper or solder coated clad metal with copper.

3.1.3 Filling materials

Filling materials shall be transparent EVA (Ethylene Vinyl Acetate) resin.

3.1.4 Front cover

Front cover shall be low iron tempered glasses whose thickness is not less than 3mm.

3.1.5 Frames

Frames shall be aluminum alloy.

3.1.6 Back cover

Back cover shall be resistant films for weather.

3.1.7 Terminal Box

The termination shall be lead wire system. The main material of the terminal box shall be Xyron 540Z resin.

3.1.8 Bypass diode

The bypass diode shall be installed in the terminal box.

3.2 Mechanical design

3.2.1 General

The design of module is suitable for long-term operation in general open-air climates.

3.2.2 Interconnection of solar cells

The all solar cells shall be interconnected in series using the interconnectors described in 3.1.2.

3.2.3 Termination

The termination shall be lead wire type with 4.0mm². Connector is Multi Contact connector (Model No.PV-KBT3 II ,PV-KST3 II).

3.2.4 Mass

The typical mass of modules is shown in the appended data sheet.

3.2.5 Dimension

The tolerance in dimension of modules is shown in Fig.1 and Fig.2.

3.3 Identification and product marking

The nameplate label as the identification and product marking is shown in Fig.3.

3.4 Appearance

The following shall be considered to be major visual defects:

- 1) Broken or cracked windows;
- 2) In case of the possibility that the crack may presumably deteriorate more than 10% of the effective area of the cell, which may result in the loss of power generation;
- 3) Bubbles or delamination forming a continuous path between any part of the electrical circuit and the edge of the module;
- 4) Loss of mechanical integrity, to the extent that the installation and/or operation of the module would be impaired.

3.5 Performance characteristics

3.5.1 Environmental requirement

3.5.1.1 Storage temperature

The Storage temperature of the modules shall be from -40°C to +90°C.

3.5.1.2 Operating temperature of solar cells

The operating temperature of solar cells shall be from -40°C to +90°C.

3.5.1.3 Storage humidity

The Storage humidity of the modules shall be less than 90% of relative humidity.

3.5.2 Electrical performance

3.5.2.1 Electrical output

The electrical characteristics of the module under standard test conditions (irradiance of 1000W/m² with IEC904-3 reference solar spectral irradiance distribution, AM1.5 spectrum and cell temperature of 25°C) in accordance with IEC904-1, shall be in compliance with the following table. When the maximum power is 183.0W, the electrical characteristics (open circuit voltage, maximum power voltage, short circuit current, maximum power current, maximum power) are shown in the appended data sheet. Detail procedure of measurement shall be done in accordance with SS-S Inspection 1000.

Table. electrical characteristics

Characteristic	Symbol	Min.	Unit
Maximum power	P _m	173.9	W

The above electrical characteristics are based on the result of the production line test.

3.5.2.2 Insulation

When the module shall be applied 3000V-DC (maximum system voltage: 1000V-DC) by the tester during 1min, the module shall not break down regarding the insulation.

3.5.3 Mechanical performance

3.5.3.1 Withstanding mechanical load

After the front of the module shall be loaded with 2400Pa, there shall be no major visual defects of the module described in 3.4.

3.5.3.2 Withstanding twist

After the module shall be presented the twist described in IEC61215:04.1993, there shall be no major visual defects of the module described in 3.4.

3.5.3.3 Withstanding the impact of hailstone

After a steel ball having a mass of 227±2g, a diameter of about 38mm and smooth surface shall be dropped from a height of 1m, without applying any force, on the center of the front cover, there shall be no major visual defects of the module described in 3.4.

3.5.3.4 Robustness of termination

The termination of the module has enough strength against external forces described in IEC61215:04.1993.

4. SHIPPING TEST

Each shipping lot shall successfully pass the shipping tests below.

4.1 Test executed to all shipping lots.

4.1.1 Test items

The maximum power (P_m) is measured in the production line process.

4.2 Extraction test

4.2.1 The Sampling way

Sampling shall be done by extracting at random 8 sets from 500 sets of production articles.

4.2.2 Test items

Test items shall be the dimension, the appearance and the Insulation tests.

5. PREPARATION FOR DELIVERY

5.1 The shipping carton box specification

The shipping carton box specification is shown in Fig.4 and Fig.5.

5.2 Identification of serial number

The serial number label is indicated in one place of front glass and is stuck to carton box.

6. WARNING

The items regarding the warning are shown in the appended data sheet.

7. OTHERS

Any doubt as to this specification shall be determined in good faith upon mutual consultation of the both parties.

SHARP

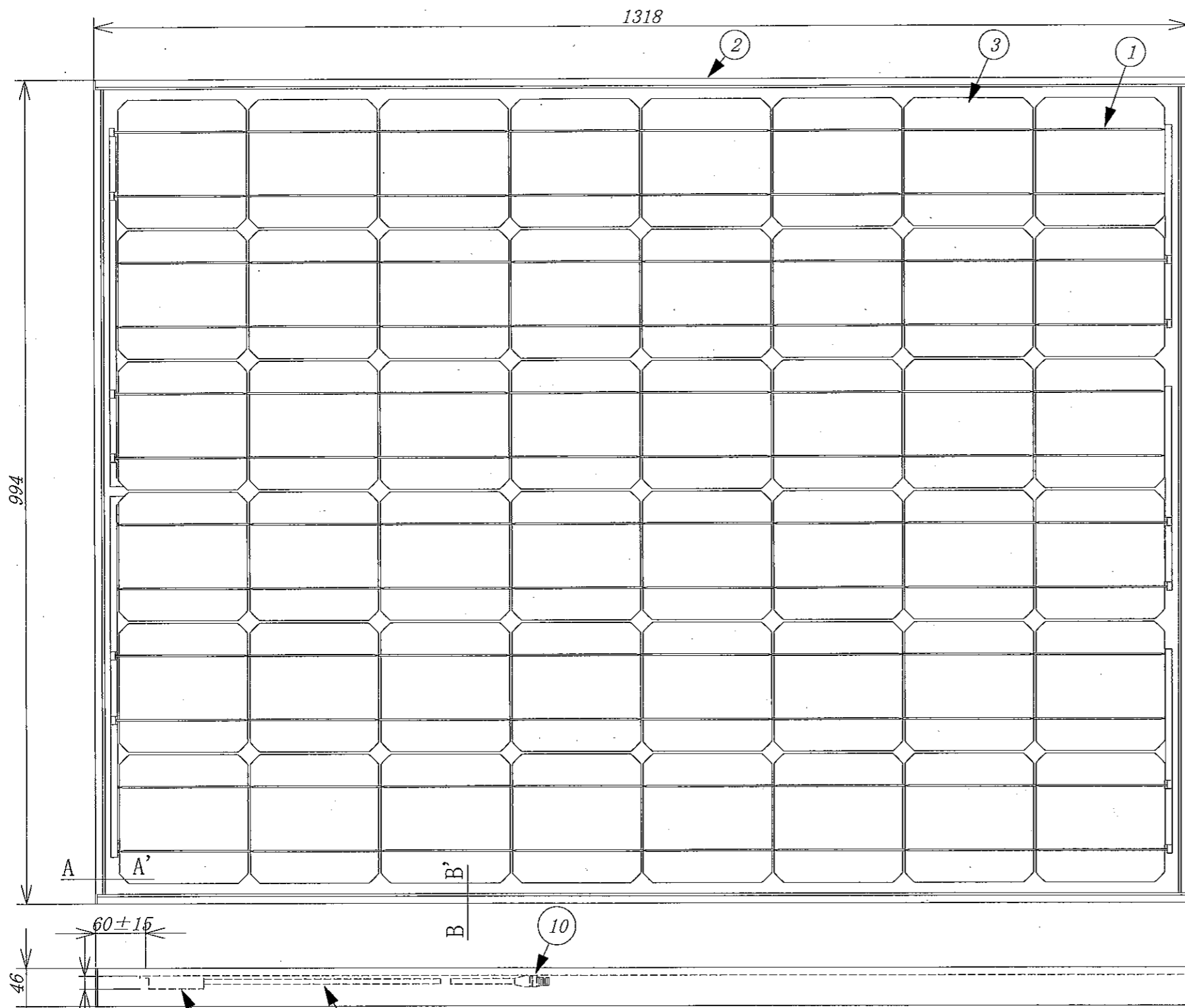

No	NAME	PIECES	MATERIALS
1	Inter-Connector		Cu or Clad metal with copper
2	Frame	4	AL (Silver color)
3	Solar Cell	48	Si (Black Color group)
4	Terminal Box	1	Xyron 540Z
5	Glass	1	Low Iron tempered glass
6	Resin		EVA
7	Back Cover		Weatherproof Film
8	Side Seal		Rubber
9	Electric Output cable	2	4.0mm ² , L=900mm±50mm
10	Connector		TPE (Thermoplastic elastomer)
11	Screw	8	Stainless Steel

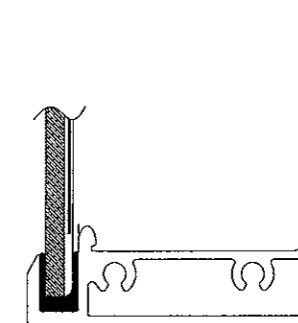

B-B' Cross Section

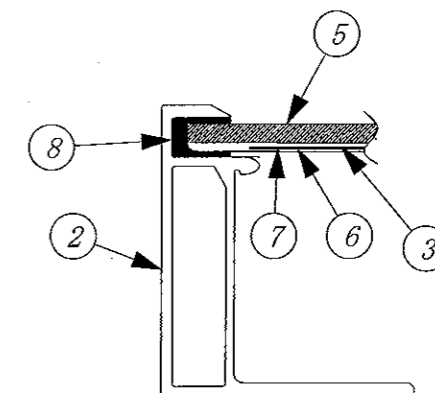

A-A' Cross Section

Permissible deviations in dimensions without tolerance indication is shown in table A.

Table A

Dimension : L	Permissible Deviation
0.5 < L < 3	+0.2
3 < L < 6	+0.3
6 < L < 30	+0.5
30 < L < 120	+0.8
120 < L < 400	+1.2
400 < L < 1000	+2
1000 < L < 2000	+3
2000 < L < 4000	+4

Fig. 1

適用機種 APPLICABLE MODEL	尺度 SCALE 1 : 6	単位 UNIT mm	改訂日 DATE 06.02.06	改訂記事 REVISE First Issue	担当 CHARGE Y. Fukuda
板厚 THICKNESS	員数 PIECES	材質 MATERIAL	仕上 FINISH	名称 NAME Solar Module (Front View) NU-183E1	コード CODE
Revise Date	DESIGN	CHECK	CHECK	承認 APPROVE SOLAR SYSTEMS DIVISION SOLAR SYSTEMS GROUP SHARP CORPORATION	図番 DRAWING No. TMSSF06012

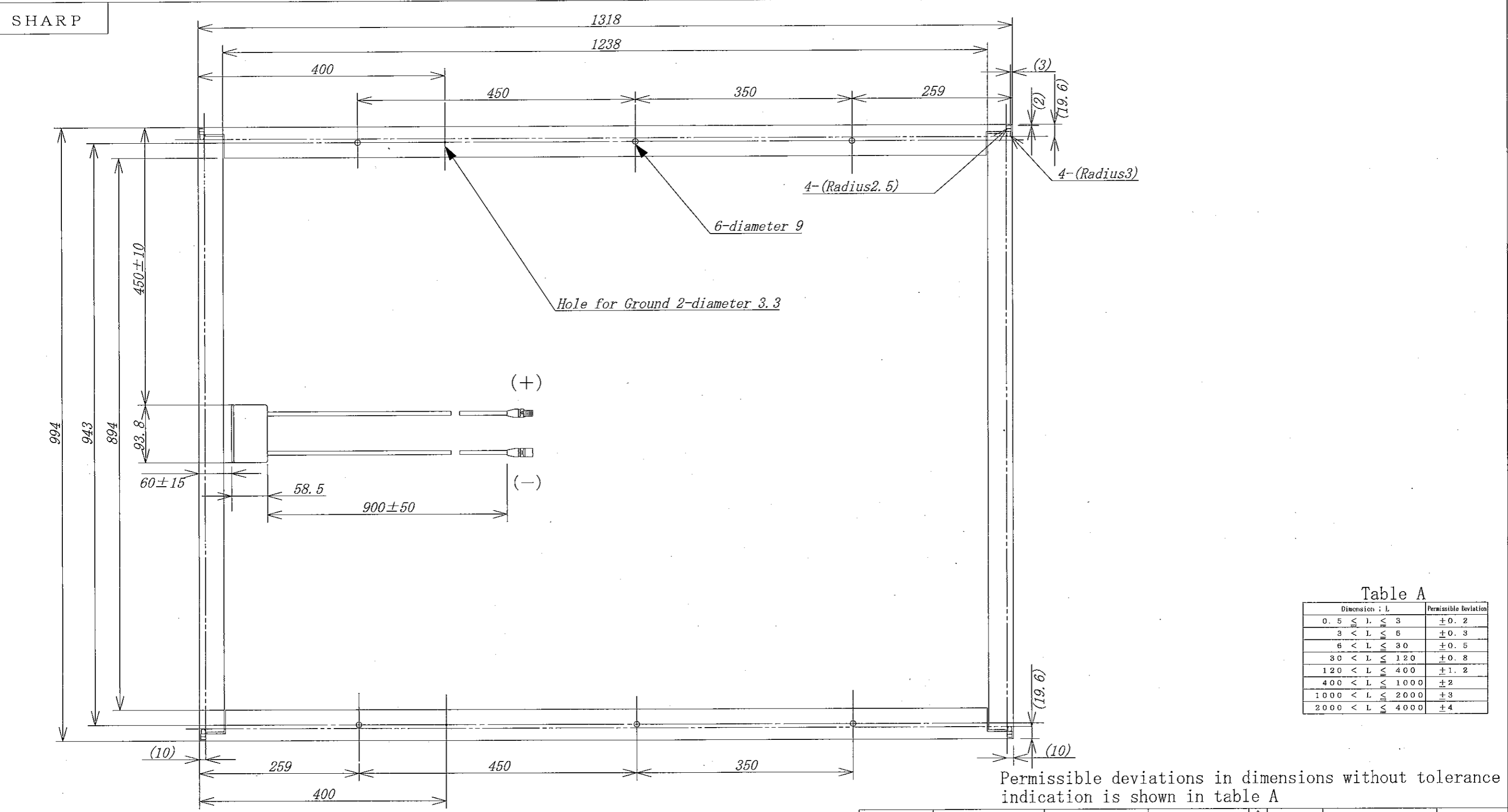

Table A

Dimension : L	Permissible Deviation
0.5 ≤ L ≤ 3	±0.2
3 < L ≤ 6	±0.3
6 < L ≤ 30	±0.5
30 < L ≤ 120	±0.8
120 < L ≤ 400	±1.2
400 < L ≤ 1000	±2
1000 < L ≤ 2000	±3
2000 < L ≤ 4000	±4

Permissible deviations in dimensions without tolerance indication is shown in table A

Fig. 2

適用機種 APPLICABLE MODEL	尺度 SCALE 1 : 6	単位 UNIT mm	改訂日 DATE 06.02.06	改訂記事 REVISE First Issue	担当 CHARGE Y. Fukuda
板厚 THICKNESS	員数 PIECES	材質 MATERIAL	仕上 FINISH	名称 NAME Solar Module (Back View)	コード CODE NU-183E1
設計 DESIGN DESIGN	検図 CHECK CHECK	検図 CHECK CHECK	承認 APPROVE APPROVE	図番 DRAWING No. TMSSF06013	
SOLAR SYSTEMS DIVISION			SHARP CORPORATION		

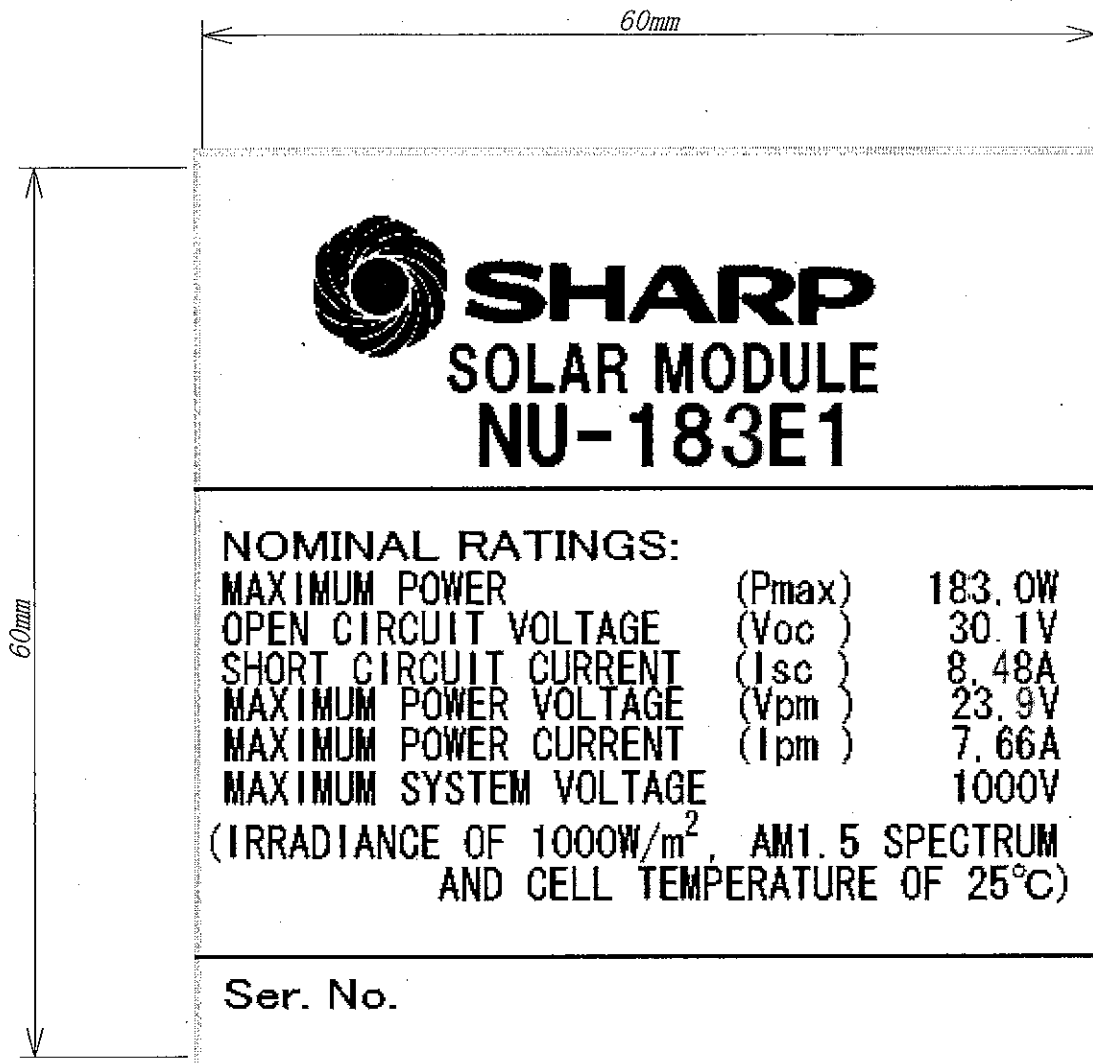

Fig. 3

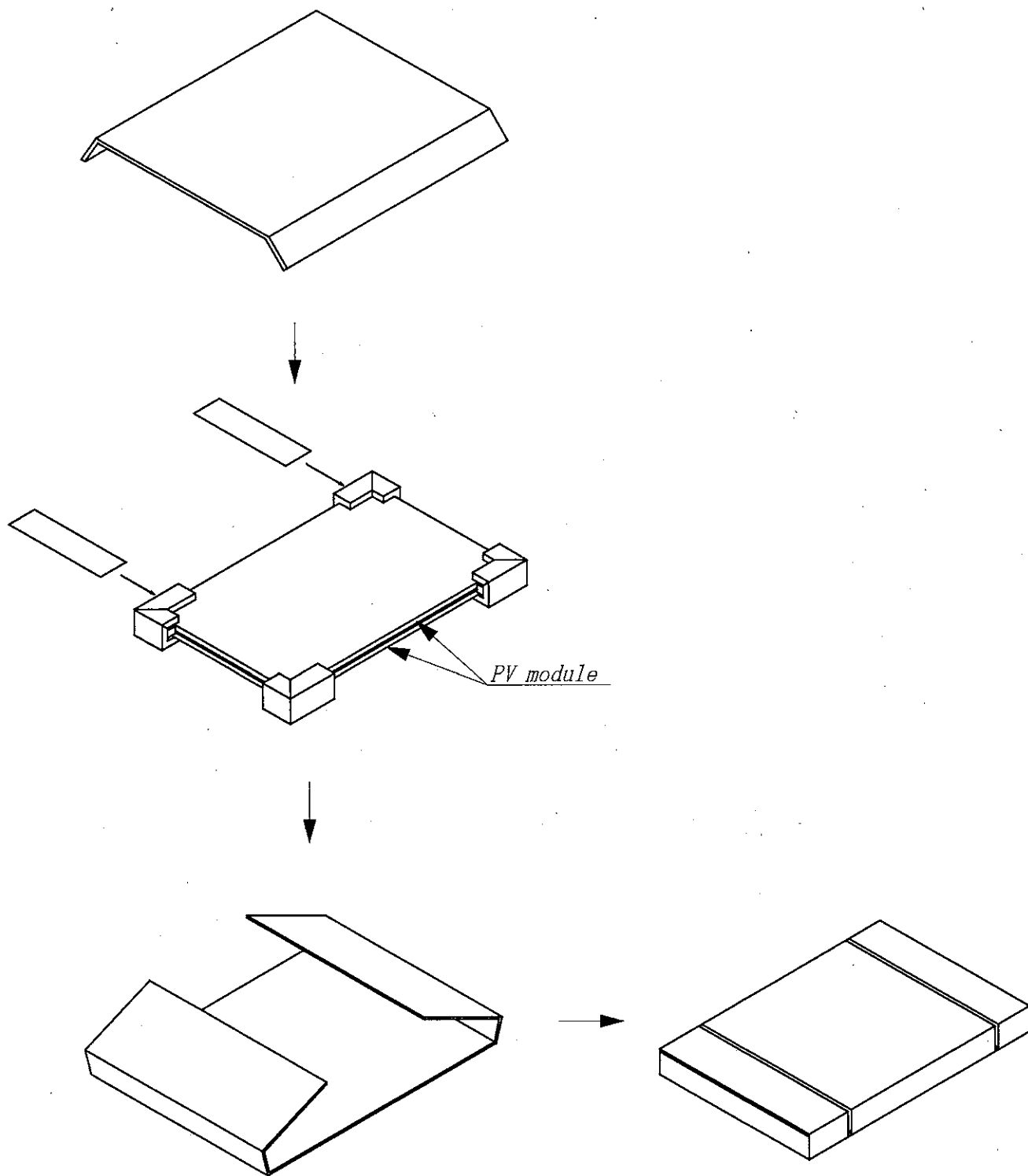

Fig. 4

SHARP
SOLAR MODULE

NU-183E1



DO NOT CONNECT DIRECTLY WITH MOTOR

QUANTITY:2

SHARP

NU-183E1

SOLAR MODULE

HANDLE WITH CARE

 **ATTENTION**

THIS PACKAGE IS VERY HEAVY. DO NOT USE THE BANDING STRAPS TO PICK UP THIS PACKAGE. IF THE BANDS BREAK, THE PACKAGE AND CONTENTS MAY BE DAMAGED, AND/OR YOU MAY BE INJURED.



SHARP ELECTRONIC DEVICE

DO NOT CONNECT DIRECTLY WITH MOTOR

SHARP

NU-183E1

SHARP
SOLAR MODULE

Fig. 5

《APPENDED 1》

Data Sheet

I -1. SCOPE

This data sheet describes the standard information (not items guaranteed) except specifications for the detail design and work. Users shall consider the other information.

I -2. MASS

The typical mass of the module is 16.0 kg.

I -3. ELECTRICAL OUTPUT

When the maximum power is 183.0 W, the electrical characteristics of the module under standard test conditions are shown in the following table.

Table. electrical characteristics

Characteristics	Symbol	@183.0W	Unit
Open circuit voltage	Voc	30.1	V
Maximum power voltage	Vpm	23.9	V
Short circuit current	Isc	8.48	A
Maximum power current	Ipm	7.66	A
Maximum power	Pm	183.0	W

The above electrical characteristics are based on the result of the production line test. These electrical characteristics are different from the rated electrical characteristics described in the name plate label. There electrical characteristic of the module under not standard test condition is shown in the following.

- (1) Fig. I -1:Characteristics regarding Open circuit voltage and short circuit current versus Irradiance
- (2) Fig. I -2:Characteristics regarding Current and Power versus Voltage per Irradiance
- (3) Fig. I -3:Normalized characteristics regarding Open circuit voltage ,Short circuit current and Maximum power versus Cell temperature

I -4. WARNING

Please obey the instructions mentioned below for actual use of this module.

I -4.1 Use

- (1) Main applications of the modules as follows.
 - Telemeter system • Microwave repeater station
 - Other telecommunication system (Terminal)
 - Village electrification • Monument • Toy etc

- (2) Please take proper steps in order to maintain reliability and safety, in case this module is used for the uses or in areas mentioned below which require high reliability.
- Fallen snow area
 - Extremely cold area
 - Strong wind area
 - Over water
 - Always poured water area
 - Salt water damage area
 - Small island
 - Desert area
 - Unit concerning control and safety of a vehicle (air plane, train, automobile etc.)
 - Traffic signal
 - Road sign
 - Security system
 - Other safety system
 - etc
- (3) Please don't use for the uses mentioned below which require extremely high reliability.
- Space equipment
 - Telecommunication system (Trunk)
 - Nuclear control system
 - Medical system (relating to any fatal element)
 - etc.
- (4) Please do not connect the modules directly to the loads such as motor since the variation of the output power depending on the solar irradiation causes the damage for the connected motor.
- 1: In case of brush-less motor, the lock function gets active and the hall IC is most likely to be damaged.
- 2: In case of the motor with brush, the coil is most likely to be damaged.

I -4.2 Handling

- (1) Never touch the output terminals with bare hands when the module is irradiated. Cover the surface of the module by sufficiently thick cloth or something suitable to prevent incident light, and handle the output terminals with rubber-gloved hands not to receive the electric shock.
- (2) Do not drop tools or hard things on the front cover of the module. When broken the front cover of the module, never use the module.
- (3) Do not scratch the back cover by hard things. Do not wear a metallic jewelry which may become cause of the electric shock during installation.

I -4.3 Installation

- (1) When mounting the module on structure, keep the displacement of the forth corner of the module smaller than 2mm for 1000mm of the diagonal of the module after other 3 corners are placed on structure.
- (2) Be careful in handling polarity of insulated output wires.
- (3) Install modules and ground frames (support structure) in accordance with applicable law of each country.
- (4) Consult the government office before the installation of the modules in case that the permission of the installation is required by law.
- (5) The modules shall be installed and maintained by qualified personnel.
- (6) Follow safety precautions of the battery manufacturer if batteries are used with modules.
- (7) Consult manufacturer for proper installation on special vehicles such as boats and campers.

- (8) Module shall be fastened with 4C-holes with M8-bolts for withstanding load 2400Pa.
- (9) Please do not block up D-holes on the establishment.

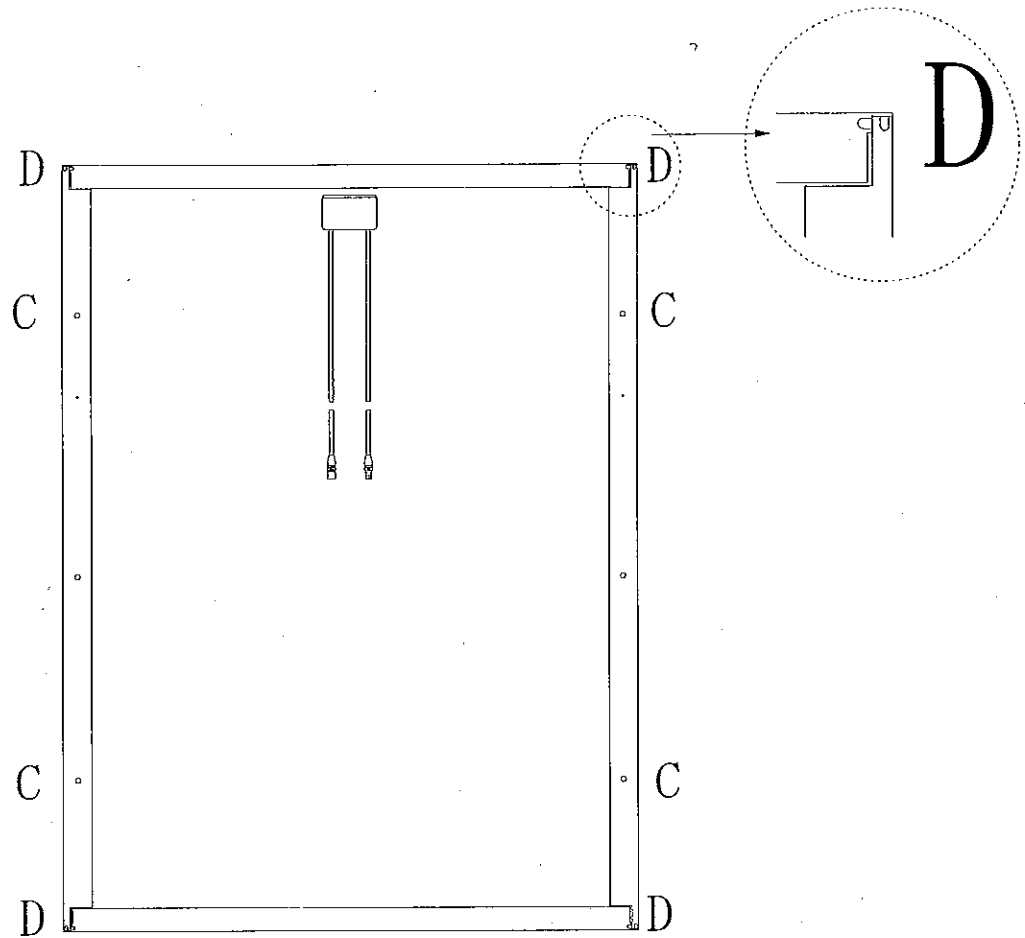

I -4.4 Operation

- (1) When a part of the modules is shadowed, the hot spot may be caused. Therefore do not shadow cells.
- (2) The modules shall be maintained by qualified personnel.
- (3) The electrical characteristics degrade when the front cover of the module becomes dirty.
- (4) Do not pour solvent on the modules when cleaning.
- (5) Do not produce sparks near flammable vapors.
- (6) Do not expose the modules to sunlight concentrated with mirrors, lenses or similar means.
- (7) Keep modules away from children.

Model : NU-183E1
 (Cell Temperature : 25°C)

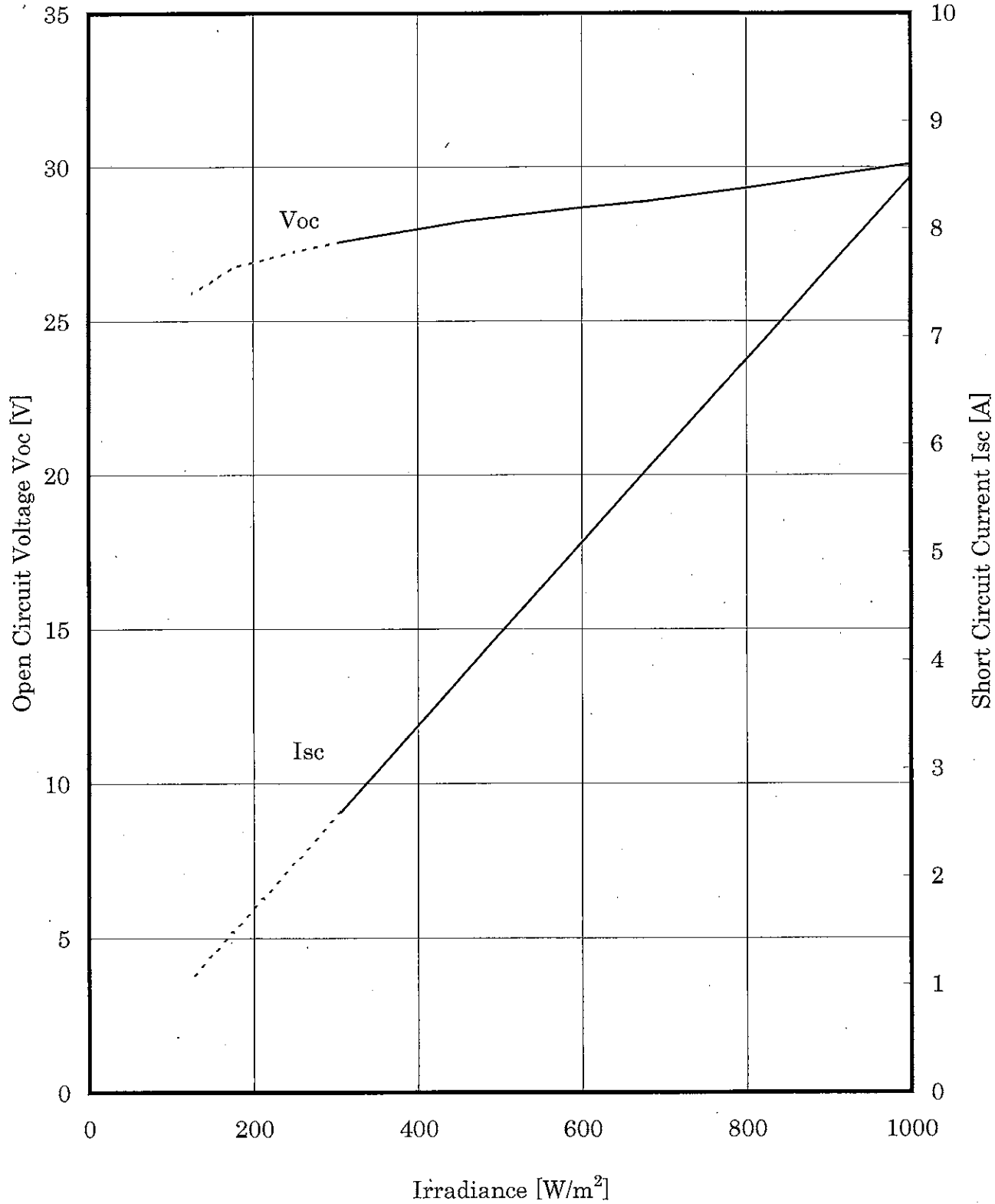

Fig. I -1 Open Circuit Voltage , Short Circuit Current vs. Irradiance Characteristics

Model : NU-183E1
 (Cell Temperature : 25°C)

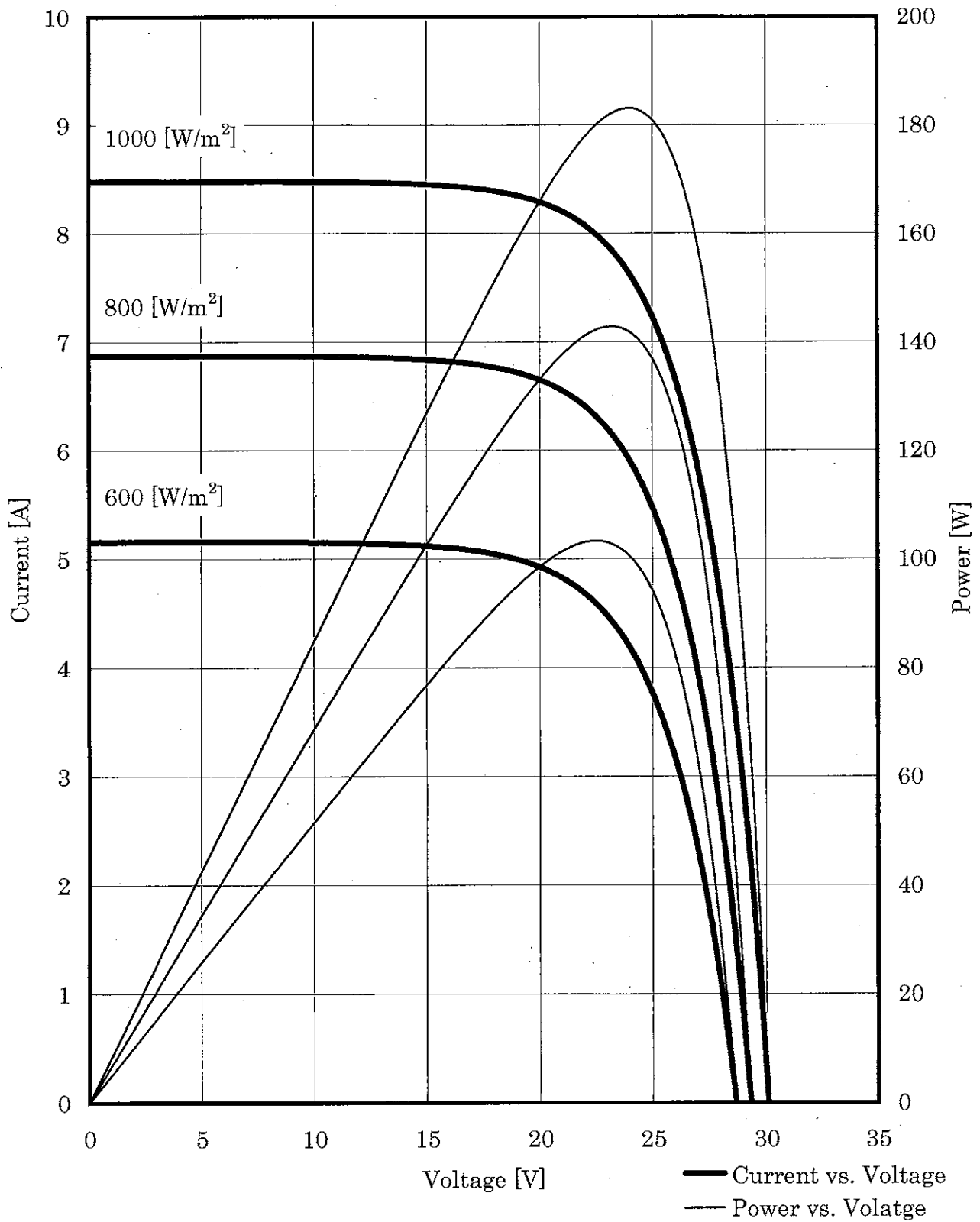

Fig. I -2 Current , Power , vs. Voltage Characteristics

Model : NU-183E1

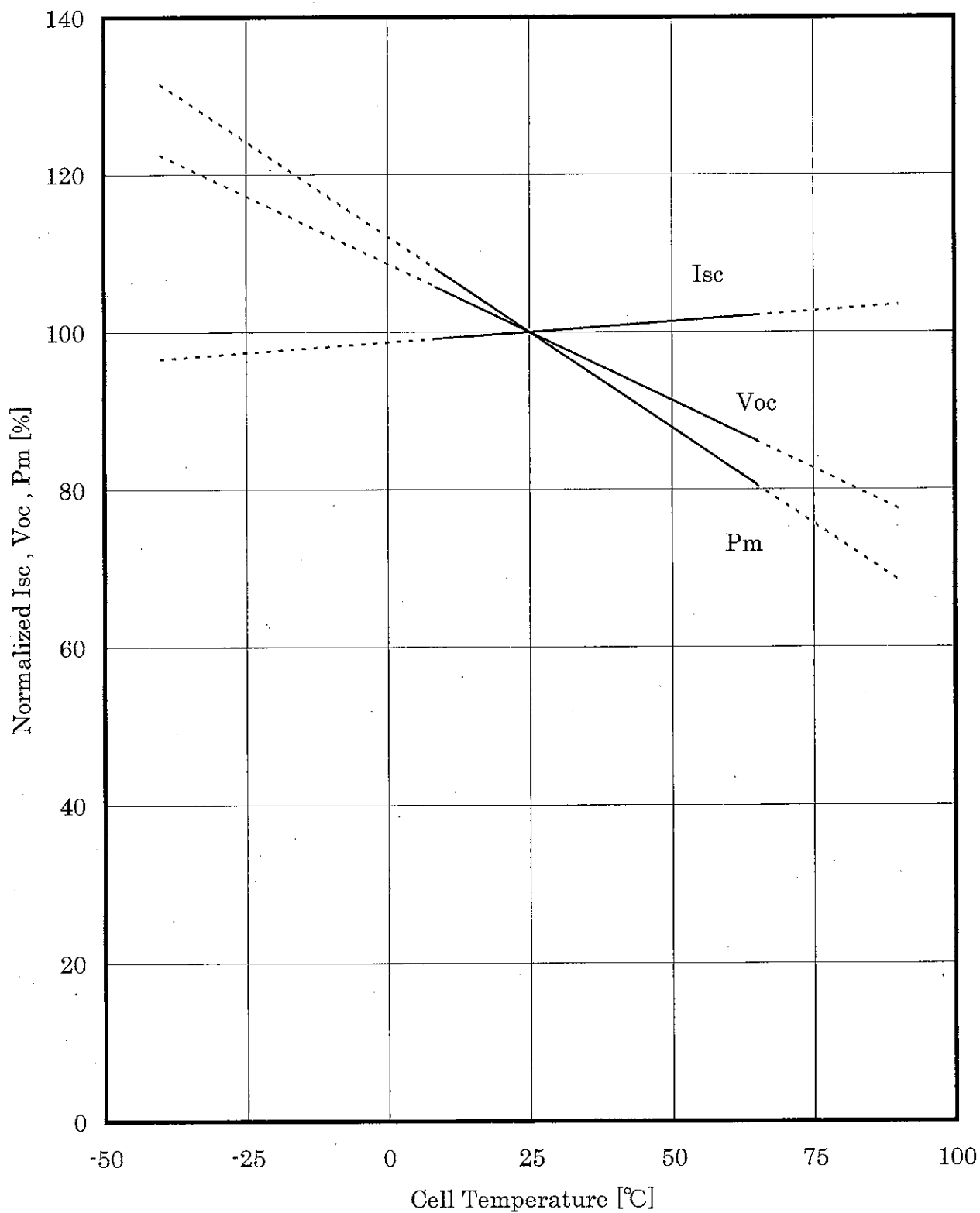

Fig. I -3 Normalized Isc , Voc , PM vs Cell Temperature Characteristics